



US006878162B2

(12) **United States Patent**  
**Bales et al.**

(10) **Patent No.:** **US 6,878,162 B2**  
(45) **Date of Patent:** **Apr. 12, 2005**

(54) **HELICAL STENT HAVING IMPROVED FLEXIBILITY AND EXPANDABILITY**

(75) Inventors: **Thomas O. Bales**, Coral Gables, FL (US); **Peter K. Kratsch**, Sunrise, FL (US); **Kenneth E. Perry**, Bainbridge Island, WA (US)

(73) Assignee: **Edwards Lifesciences AG**, Horw (CH)

(\* ) Notice: Subject to any disclaimer, the term of this patent is extended or adjusted under 35 U.S.C. 154(b) by 200 days.

(21) Appl. No.: **10/231,666**

(22) Filed: **Aug. 30, 2002**

(65) **Prior Publication Data**

US 2004/0044401 A1 Mar. 4, 2004

(51) **Int. Cl.**<sup>7</sup> ..... **A61F 2/06**

(52) **U.S. Cl.** ..... **623/1.15; 623/1.22**

(58) **Field of Search** ..... 606/191, 192, 606/194, 198; 623/1.15, 1.16, 1.18, 1.2, 1.22

(56) **References Cited**

**U.S. PATENT DOCUMENTS**

5,913,897 A 6/1999 Corso, Jr. et al. .... 623/1  
6,042,597 A 3/2000 Kveen et al. .... 606/198  
6,129,755 A 10/2000 Mathis et al. .... 623/1.15

6,190,406 B1 2/2001 Duerig et al. .... 623/1.2  
6,245,100 B1 6/2001 Davila et al. .... 623/1.13  
6,342,067 B1 1/2002 Mathis et al. .... 623/1.15  
6,348,065 B1 2/2002 Brown et al. .... 623/1.16  
2002/0035394 A1 3/2002 Fierens et al.

**FOREIGN PATENT DOCUMENTS**

EP 1155664 A2 \* 11/2001 ..... A61F/2/06  
EP 1132058 12/2001 .....  
WO WO 200016718 A1 \* 3/2000 ..... A61F/2/06  
WO PCT/US01/16431 5/2001 ..... A61F/2/06

\* cited by examiner

*Primary Examiner*—Brian E Pellegrino

(74) *Attorney, Agent, or Firm*—Rajiv Yadav

(57) **ABSTRACT**

A stent includes a central portion of helically wound undulations formed of struts, cylindrical end portions, and transition zones between the helical portion and the cylindrical portions. According to a first aspect of the invention, the torsional flexibility of the stent is maximized by having bridges connecting adjacent winding be interrupted by the maximum possible number of undulations. In a preferred design, each winding includes nineteen undulations around the circumference, bridges are provided every five undulations. According to a second aspect of the invention, uniform opening of the transition zone is achieved by altering the width, and thereby the flexibility, of a series of struts in accordance with their lengths. Specifically, the long transition zone struts are made wider.

**20 Claims, 3 Drawing Sheets**

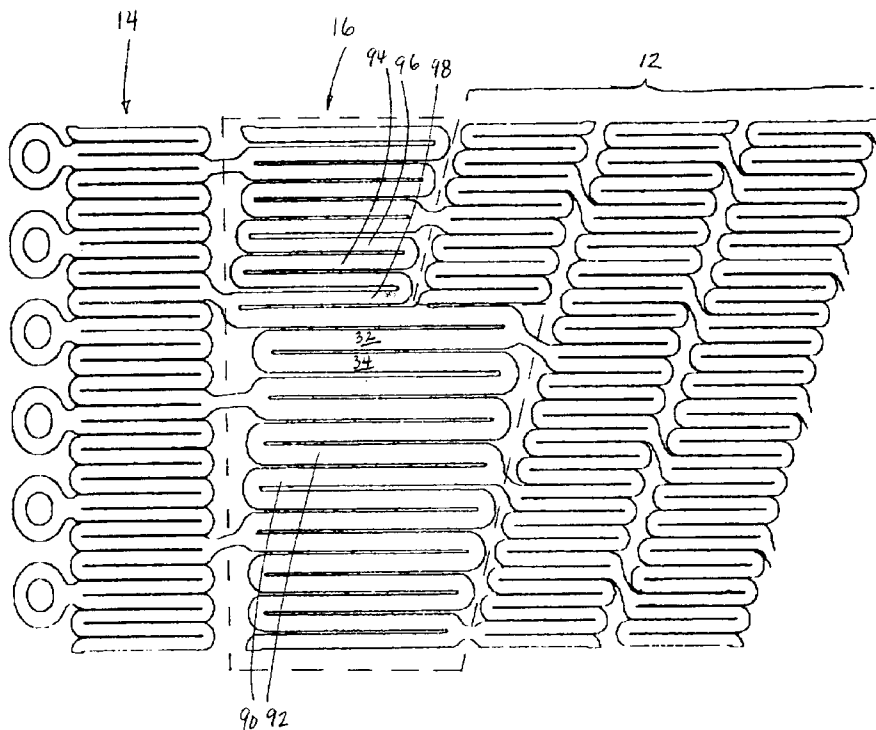

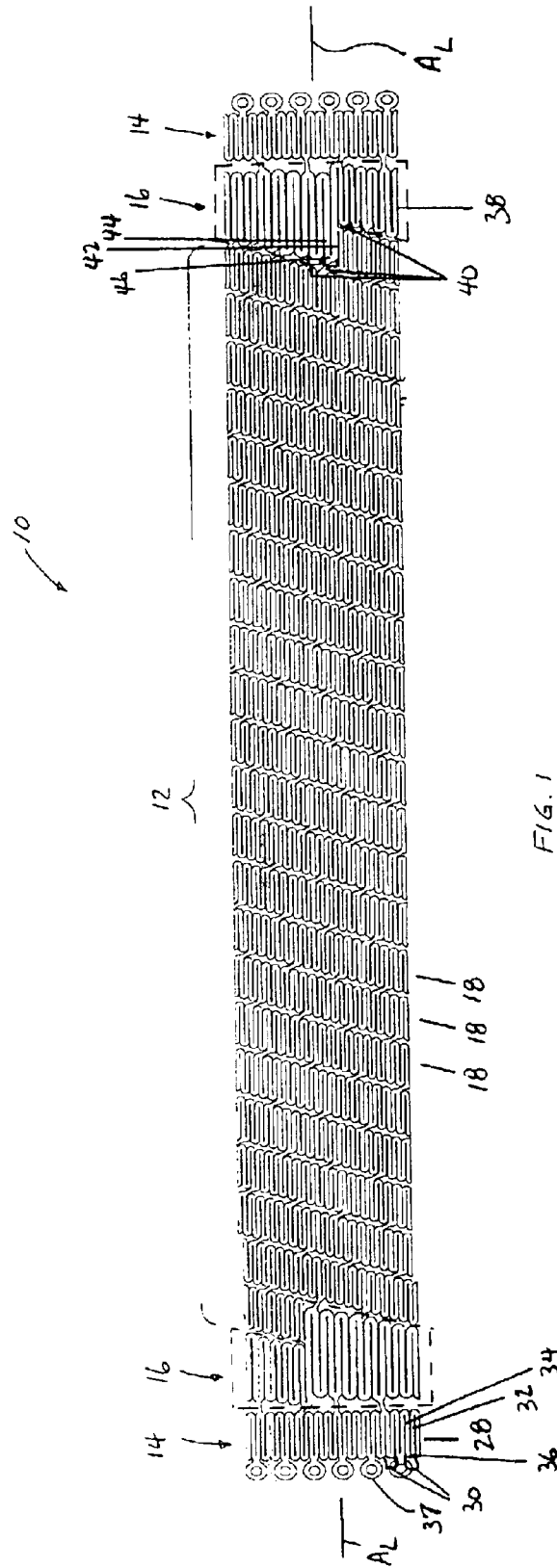

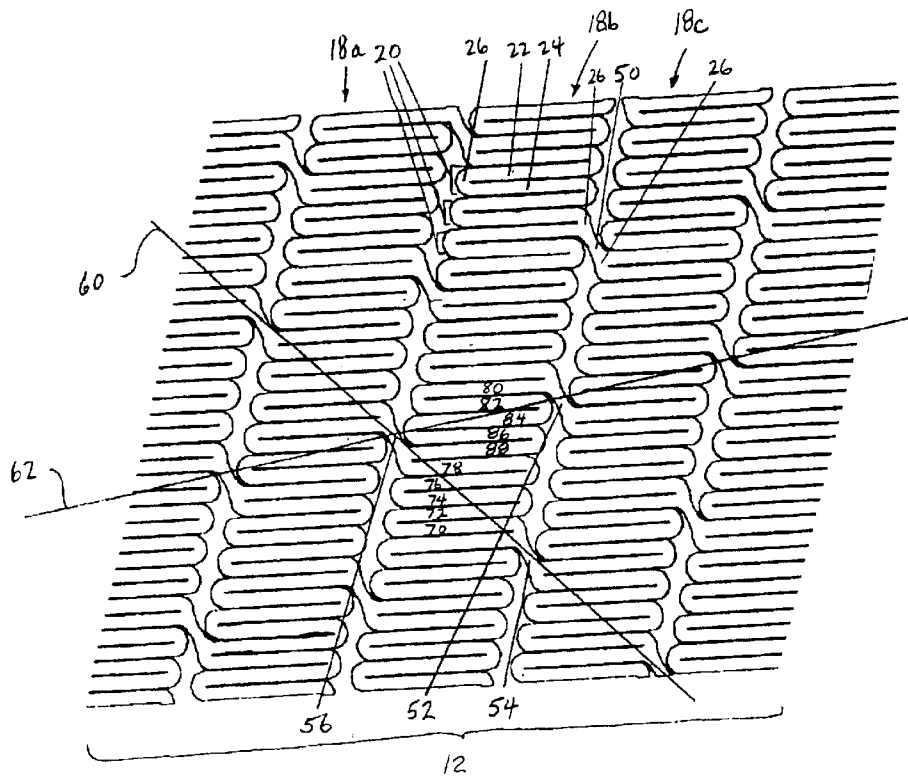

FIG. 2

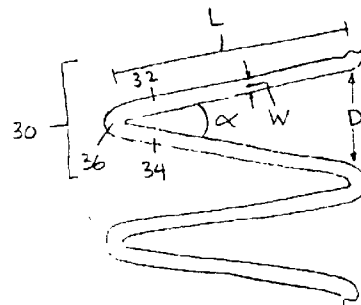

FIG. 4

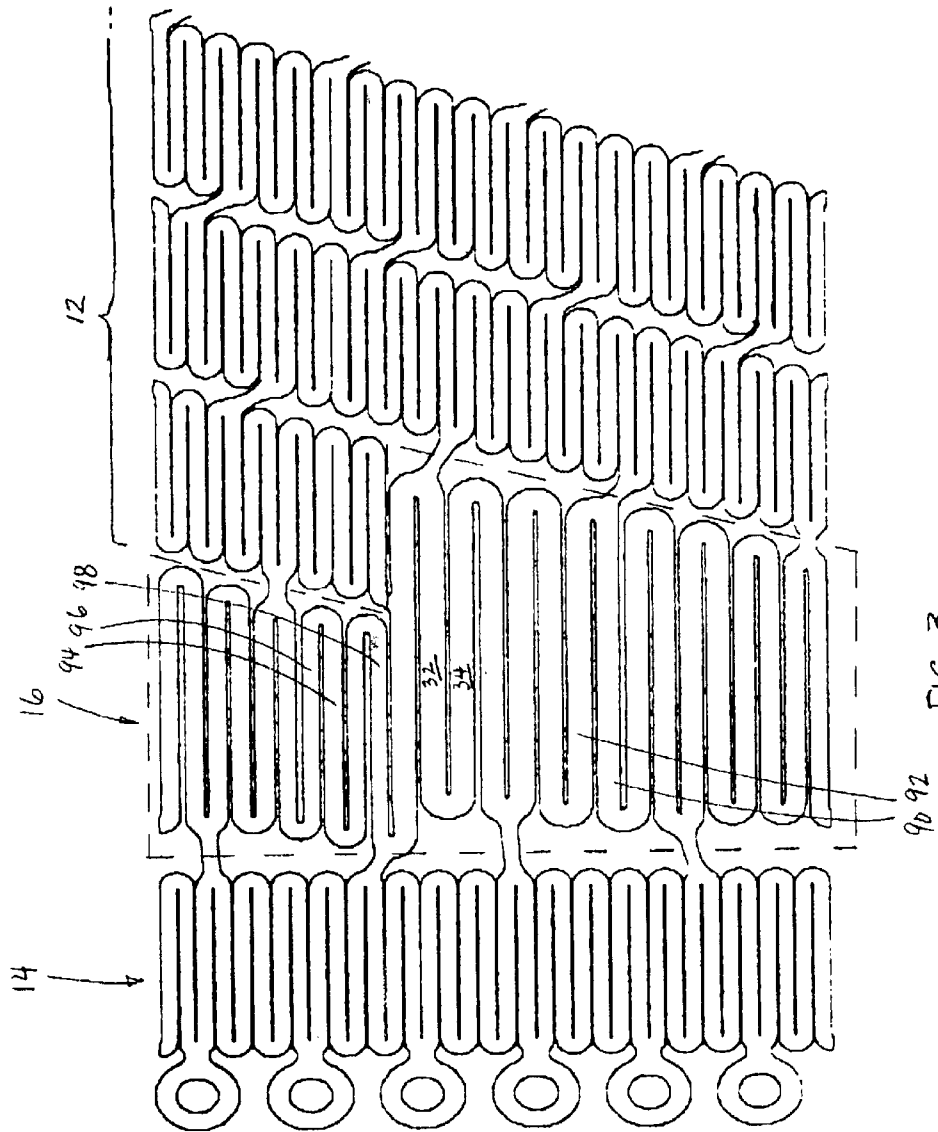

FIG. 3

## HELICAL STENT HAVING IMPROVED FLEXIBILITY AND EXPANDABILITY

### BACKGROUND OF THE INVENTION

#### 1. Field of the Invention

This invention relates broadly to arterial prosthesis. More particularly, this invention relates to vascular stents, and even more particularly to helical stents.

#### 2. State of the Art

Transluminal prostheses are widely used in the medical arts for implantation in blood vessels, biliary ducts, or other similar organs of the living body. These prostheses are commonly known as stents and are used to maintain, open, or dilate tubular structures.

Stents are either balloon expandable or self-expanding. Balloon expandable stents are typically made from a solid tube of stainless steel. Thereafter, a series of cuts are made in the wall of the stent. The stent has a first smaller diameter configuration which permits the stent to be delivered through the human vasculature by being crimped onto a balloon catheter. The stent also has a second, expanded diameter configuration, upon the application, by the balloon catheter, from the interior of the tubular shaped member of a radially, outwardly directed force.

Self-expanding stents act like springs and recover to their expanded or implanted configuration after being compressed. As such, the stent is inserted into a blood vessel in a compressed state and then released at a site to deploy into an expanded state. One type of self-expanding stent is composed of a plurality of individually resilient and elastic thread elements defining a radially self-expanding helix. This type of stent is known in the art as a "braided stent". Placement of such stents in a body vessel can be achieved by a device which comprises an outer catheter for holding the stent at its distal end, and an inner piston which pushes the stent forward once it is in position. However, braided stents have many disadvantages. They typically do not have the necessary radial strength to effectively hold open a diseased vessel. In addition, the plurality of wires or fibers used to make such stents could become dangerous if separated from the body of the stent, where it could pierce through the vessel.

Therefore, recently, self-expanding stents cut from a tube of superelastic metal alloy have been manufactured. These stents are crush recoverable and have relatively high radial strength. U.S. Pat. No. 5,913,897 to Corso, U.S. Pat. No. 6,042,597 to Kveen, and WPO Patent Application WO 01/89421-A2 (with inventors Cottone and Becker, and referred to herein as "Cottone") each teach superelastic cut-tubular stents having a helically wound configuration of repeating undulations. Bridge structures connect adjacent circumferential windings by extending between loop portions of undulations on adjacent windings. However, the bridge structures and arrangements do not maximize the torsional flexibility of the stents. In particular, Cottone describes a stent having a helical pattern of bridges (connections) connecting windings of the helix which is reverse in handedness from the undulations of the windings which form the central portion of the stent. The design described provides the stent with asymmetric characteristics that cause the stent to resist torsional deformations differently in one direction versus the other. In addition, each "helix of connections" forms a string of connections in which the connections are interrupted by only one and one-half undulations. As such, that string is resistant to

stretching and compression. Accordingly, when a stent so designed is twisted torsionally, that string of connections causes constriction of the stent when twisted in the "tightening" direction (i.e., in the direction of the windings) and expansion of the stent when twisted in the opposite "loosening" direction. This differential torsional reaction results in the undulations of the stent being forced out of the cylindrical plane of the surface of the stent, such that the stent appears to buckle when twisted in the "loosening" direction.

In fact, even if the stent were constructed opposite to Cottone's preferred embodiment (that is, with a helix of bridges having the same handedness as the helix of undulations), the same effect results. Stents built with constructions containing a string of bridges separated by only a small number of undulations behave poorly when twisted. That is, they react differently if the stent is twisted one way versus the other, and the surface of the stent tends to buckle when twisted only slightly in the "loosening" direction.

Moreover, due to the helical windings of the stents, the stents described by Corso and Kveen terminate unevenly at the end of the helical windings. As such, the terminus of the final winding fails to provide a uniform radial expansion force 360° therearound. Cottone addresses this problem by providing a stent constructed with a helically wound portion of undulations in the central portion of the stent, a cylindrical portion of undulations at each end of the stent, and a transition zone of undulations joining each cylindrical portion to the central helically wound portion. The undulations of the transition zone include struts which progressively change in length.

Because the transition zone must mate directly to the cylindrical portion on one side and to a helically wound portion on the other side, the transition zone must create a free end from which the helical portion extends, must contain a bifurcation, and must depart from a uniform strut length for the struts around the circumference of the transition zone so that the transition from the helically wound portion to the cylindrical portion can occur.

However, if there are longer struts in a portion of the transition zone, that portion tends to expand more than the portion with shorter struts because the bending moments created by longer struts are greater than those created by shorter struts. Also, for the same opening angle between two such struts when the stent is in an expanded state, the opening distance between such struts is greater if the struts are longer. These two factors combine their effects in the portion of the transition zone with longer struts so that the apparent opening distances are much larger than in the portion where the struts are shorter. As such, the simple transition zone described by Cottone is not amenable to uniform expansion and compression, which is a requirement of an efficient self-expanding stent.

Moreover, except in the case of the Cottone helical stent which is provided with a transition zone, and except where there are different strut lengths in the undulations at the ends of a stent, stents generally contain struts of one length throughout their design. Accordingly, in order to achieve uniform opening of the stent, all the struts have substantially the same width as well as length.

### SUMMARY OF THE INVENTION

It is therefore an object of the invention to provide a cut-tube self-expanding helical stent which has substantially equal torsional flexibility and resistance to torsional buckling when twisted in both directions.

It is another object of the invention to provide a cut-tube self-expanding helical stent having a transition zone and a cylindrical segment at each end thereof, and to improve the expandability of the transition zone.

It is a further object of the invention to provide a cut-tube self-expanding helical stent having a transition zone in which openings created between the struts of an expanded stent can be made more uniform over the entire transition zone.

In accord with the invention, which will be described in detail below, a cut-tube self-expanding stent having a central helically wound portion comprising repeating undulations formed of struts is provided at each of its ends with a cylindrical portion, and a transition zone between the helical portion and each cylindrical portion.

According to a first aspect of the invention, several criteria are set forth which together provide for optimal torsional flexibility and expandability in a self-expanding helically wound stent. According to a first criterion, the torsional flexibility of the stent is maximized by having all the "strings" of bridges which connect adjacent helical winding be interrupted by the maximum possible number of undulations. This results in these bridge strings being as stretchy and compressible as possible. According to a second criterion, the undulations in the central portion are interdigitated. According to a third criterion, preferred numbers of undulations, bridges, and undulations between bridges are provided. According to a fourth criterion, the bridges preferably extend in a "short" direction, longitudinally crosswise across the helically space separating the helical windings of undulations. Most preferably, the bridges join loops of undulations which are out of phase by one and one-half undulations.

According to a second aspect of the invention, uniform opening of the transition zone is achieved by altering the flexibility of a series of struts in accordance with their lengths. Specifically, the long transition zone struts are made wider (in the cylindrical plane) to compensate for the greater bending moments imposed by the longer struts. This keeps the opening distance (the distance between the open ends of adjacent struts in an expanded stent) approximately constant throughout the transition zone. More particularly, in a typical transition zone, the shortest strut must be approximately half the length of the longest strut. In order to maintain similar opening distances, the long struts should be wider by approximately the cube root of 2 squared, i.e. approximately 1.59. The ratio may be adjusted to a value near this ratio in order to achieve a uniform opening, giving consideration to the fact that in a transition zone two adjacent struts of unequal length both contribute to the bending moment on the flexing connection that joins them. The ratio may also be adjusted to make the opening angle of the shortest strut pairs not exceed a certain value in order to limit the maximum strains experienced in that portion of the transition zone.

Additional objects and advantages of the invention will become apparent to those skilled in the art upon reference to the detailed description taken in conjunction with the provided figures.

#### BRIEF DESCRIPTION OF THE DRAWINGS

FIG. 1 is a broken flattened view of a helical stent according to the invention in an unexpanded state, wherein the stent has been cut parallel to its longitudinal axis and laid flat;

FIG. 2 is an enlarged broken flattened view of a central portion of the helical stent of FIG. 1;

FIG. 3 is an enlarged broken flattened view of a transition zone portion of the helical stent of FIG. 1; and

FIG. 4 is a schematic view of a plurality of struts of the transition zone of FIG. 3 shown in an open configuration.

#### DETAILED DESCRIPTION OF THE PREFERRED EMBODIMENTS

Turning now to FIG. 1, a helical stent 10 according to the invention is shown. The stent has a collapsed configuration with a first smaller diameter for insertion into a body vessel, and self-expands to an expanded or deployed configuration with a second larger diameter for deployment within the vessel. The stent is preferably a laser-cut tubular construction of a superelastic metal alloy such as nickel-titanium.

The stent 10 includes a central portion 12, a cylindrical portion 14 at each end of the stent 10, and a transition zone 16 between the central portion 12 and each cylindrical end portion 14. The central portion 12 is comprised of a plurality of helical circumferential windings (single turns of a helix) 18 of substantially like undulations (in length and width) 20, with each undulation 20 being defined by two adjacent struts, e.g., struts 22, 24, and a loop 26 connecting the struts (FIG. 2). The cylindrical end portion 14 is comprised of preferably a single cylindrical winding 28 of like undulations 30, with each such undulation 30 being defined by two adjacent struts, e.g., struts 32, 34, and a loop 36 connecting the struts. Optionally, one or more structures 37 adapted to receive or otherwise be coupled to radiopaque markers (not shown) can be provided at the ends of one or more of the undulations 30. The transition zone 16 is comprised of preferably a single winding 38 of undulations 40 that preferably progressively increase in size, with each such undulation 40 being defined by two adjacent struts, e.g., struts 42, 44, and a loop 46 connecting the struts.

In each of sections 12, 14 and 16, the undulations 20, 30, 40 extend in a generally longitudinal direction. That is, when the stent is in a collapsed configuration, as shown in FIG. 1, struts of the helical portion (e.g., 22 and 24), cylindrical portion (e.g., 32 and 34) and transition zone (e.g., 42 and 44) all extend substantially parallel to the longitudinal axis  $A_L$  of the stent. In the expanded configuration, adjacent struts are moved apart and angled relative to each other.

Referring to FIG. 2, particularly with respect to the central portion 12, as the windings 18a, 18b, 18c are longitudinally displaced along the length of the stent, bridges, e.g. 50, 52, 54 and 56, are provided to connect together the loops 26 of undulations 20 on adjacent windings, e.g. 18a and 18b, and 18b and 18c, to prevent stent unwinding. The bridges 50, 52, 54, 56 can be seen to be arranged in right-handed and left-handed helical "strings" (right-handed string 60 and left-handed string 62) which extend about the stent.

There are several preferred design considerations (criteria) which, according to the invention, are preferably used together to identify a desired number and placement of undulations in any winding and a number and placement of bridges 50, 52, 54, 56 which connect together loops 26 of undulations on adjacent windings (and thereby connect together the windings 18a, 18b, 18c). If the central portion 12 is designed in accord with the following criteria, the central portion 12 will have a desired torsional flexibility and expandability; i.e., be not too stiff, but also be sufficiently flexible so that the central portion 12 will not be subject to kinking.

In accord with a first criterion, the pattern of bridges is as symmetric as possible. That is, the right-handed and left-handed strings 60, 62 of bridges should be as similar as

possible. Further, the torsional flexibility of the stent is maximized by having each string **60**, **62** of bridges be interrupted by the maximum possible number of undulations **20**. This results in the bridge strings being as stretchy and compressible as possible. In any given stent design, there is a certain number of undulations which form a complete circumferential winding (single turns of the helical portion). The number of undulations **20** which separate the bridges lying along any one string depends, therefore, on the number of bridges within a complete circumferential winding. For example, if there are eighteen undulations around a circumferential winding and three bridges, and if the bridges on adjacent windings are staggered, in accord with the invention there should be three undulations separating bridges along each helical strings of bridges.

In accord with a second criterion, it is preferred that the loops **26** of the undulations **20** of the central portion **12** be interdigitated between the loops of the undulations on an adjacent winding. For example, if there are eighteen undulations around the circumference, each undulation would be rotationally displaced from the undulations on the adjacent winding by one-half an undulation (i.e., one thirty-sixth of a circle or ten degrees), so that the "peak" of one loop is directed into the "valley" between two loops on an adjacent winding.

In accord with a third criterion, it is necessary to observe how the number (m) of undulations between bridges and the number (n or n+1/2) of undulations around the circumference interact to create helical strings of bridges. That is, with an increase in n for a stent of a given diameter, the stent is weakened and subject to kinking. This is because, for a stent of a given diameter, by providing more struts, narrower and weaker struts must be used. As n is decreased, the struts are increased in width and thus stiffness. However, while this may strengthen the stent, the stent is nevertheless limited in flexibility and may be undesirably stiff. In accord with the invention, for the optimum combination of strength and flexibility, it is preferred that n (i.e. the number of undulations) be sixteen to twenty, and more preferably eighteen to nineteen, where n may optionally be a noninteger. In addition, the number of bridges, m, for the preferred number of struts is most preferably three to five bridges per circumferential winding.

In accord with a fourth criterion, consideration must be made as to the locations between which the bridges connect and the direction in which the bridges extend. In accord with the preferred interdigitated criterion, the bridges cannot extend parallel to the longitudinal axis  $A_L$  of the stent. Rather, they preferably extend across loops located one and one-half pitches away; i.e., each bridge connects over two struts relative to directly across from the strut from which the bridge extends. In addition, the bridges extend longitudinally crosswise across the helical space separating the adjacent loops (i.e. in a "short" direction), as opposed circumferentially along the helical space separating the adjacent loops (i.e., in a "long" direction).

In view of the above, a preferred exemplar central portion **12** of the stent **10** illustrating the application of the above criteria is now described. Referring to FIG. 2, the central portion **12** of the stent **10** includes repeating undulations **20** (each comprising two struts **22**, **24** and a loop **26**) that are helically wound in circumferential windings **18a**, **18b**, **18c**, etc. There are preferably nineteen undulations **20** in each circumferential winding **18a**, **18b**, **18c** and the undulations are interdigitated. With reference to windings **18b** and **18c**, a bridge **50**, **52**, **54** is located every five undulations therebetween, and each bridge joins loops of undulations on

the adjacent windings **18a**, **18b** which are one and one-half pitches away (or two struts over from directly across) in the "short" direction. That is, all bridges in the central portion **12** of the stent preferably extend in the same direction, longitudinally crosswise across the helical space. This preferred exemplar embodiment provides a very symmetrical distribution of bridges. In particular, traveling from any one bridge, e.g. bridge **54**, to the next bridge, e.g. bridge **56**, along the right-hand string **60** of bridges, traverses exactly two and one half undulations (or five struts **70**, **72**, **74**, **76** and **78**). Moreover, traveling from any one bridge, e.g. bridge **52**, to the next bridge, e.g. bridge **56**, along the left-handed string **62** of bridges, also traverses exactly two and one half undulations (or five struts **80**, **82**, **84**, **86** and **88**). This design gives very even torsional flexibility and expandibility, and the stent may be twisted considerably in either direction without buckling.

Referring now to FIG. 3, the transition zone **16** of the stent **10** is shown. The transition zone, as stated above, includes struts that progressively increase in length. The long transition zone struts **90**, **92** are relatively wider (in the cylindrical plane) than the shorter transition zone struts **94**, **96** to compensate for the greater bending moments imposed by the longer struts. Moreover, even the shortest transition zone strut **98** is preferably longer and wider than the struts **22**, **24** of the central portion **12**.

More particularly, referring to FIGS. 3 and 4, for substantially uniform expansion of the stent, it is desirable for the opening distance D (i.e., the distance between the ends of two adjacent struts, e.g. struts **32** and **34**, when the stent is in an open configuration) to be approximately even throughout the transition zone **16**. Accordingly, the opening angle  $\alpha$  between pairs of longer struts in the transition zone, e.g. struts **32** and **34**, must be smaller than the opening angle  $\alpha$  between shorter struts, e.g. struts **94** and **96**. In addition, the bending stiffness of the longer struts must be even greater than in proportion to their increased bending moment. The bending stiffness S of a rectangular-section beam is in proportion to the third power of the width (in the bending direction) W. As such, by way of example, in order to double the bending stiffness of a strut, the width W of the strut must be increased by the cube root of two.

The bending moment M of a strut is in linear proportion to the length L of the strut. The opening angle  $\alpha$  is proportional to the bending moment M divided by the stiffness S. The opening distance D is proportional to the product of the opening angle  $\alpha$  multiplied by strut length L. Therefore, the opening distance D is proportional to  $\alpha * L$ , which is equal to  $(M/S) * L$ . Since M is linearly proportional to L, the opening distance D is proportional to the square of L divided by stiffness S. In order to keep the opening distance D between adjacent struts (i.e., pairs of struts) equal throughout the transition zone **16**, the stiffness of the bending segments of the struts must be in proportion to the square of their lengths. Hence, the cube of the width must be proportional to the square of the length:

$$W^3 \text{ is proportional to } L^2.$$

In a preferred transition zone, the shortest strut **98** should be approximately half the length of the longest strut **32**. Therefore, in order to maintain similar opening distances, the longer struts are most preferably wider by the cube root of 2 squared, or 1.59, relative to the shorter struts. The ratio may be adjusted to a value near this ratio (e.g.,  $\pm 25\%$ , or 1.19 to 1.99) in order to achieve a uniform opening, giving consideration to the fact that in a transition zone two adjacent struts of unequal length both contribute to the bending moment on the flexing connection that joins them.

7

It may also be desirable to make the opening angle  $\alpha$  between the shortest strut pairs not exceed a certain value in order to limit the maximum strains experienced in that portion of the transition zone.

As such, uniform opening is achieved in the transition zone by altering the flexibility of a series of struts in accordance with their lengths.

There have been described and illustrated two aspects of a preferred stent relating to the helical central portion and the transition zone. While particular embodiments of the invention have been described, it is not intended that the invention be limited thereto, as it is intended that the invention be as broad in scope as the art will allow and that the specification be read likewise. Thus, the two preferred aspects (relating to the central helical portion and the transition zone) can be used together or separately. Moreover, each of the design considerations relating to the helical central portion can be used alone or together with one or more of the other considerations. It will therefore be appreciated by those skilled in the art that yet other modifications could be made to the provided invention without deviating from its spirit and scope as claimed.

What is claimed is:

**1.** A stent for insertion into a vessel of a patient, comprising:

a tubular member having a first smaller diameter for insertion into the vessel, and a second larger diameter for deployment within the vessel,

said tubular member including a central portion comprised of a plurality of helical circumferential windings separated by a helical space, each of said windings including a plurality of undulations, with each said undulation being defined by two adjacent struts and a loop connecting the struts,

wherein adjacent windings are connected with a plurality of bridges, said bridges extending across said helical space between said adjacent windings and connected to said loops of a plurality of said undulations, and

further wherein a same number of struts is traversed from any one bridge to a next bridge on each of said windings when traveling in either a right-handed or left-handed direction along each of said windings, and wherein

said tubular member includes cylindrical end portions, and a transition zone between said central portion and each of said end portions, said transition zone including a plurality of transition undulations having struts that progressively increase in length,

wherein a relatively longer strut of said transition undulations has a relatively wider width than a relatively shorter strut of said transition undulations.

**2.** A stent according to claim 1, wherein:

said loops of said undulations on adjacent windings are interdigitated.

**3.** A stent according to claim 2, wherein:

said bridges extend between loops located one and one-half pitches away.

**4.** A stent according to claim 1, wherein:

said central portion of said stent includes sixteen to twenty undulations.

**5.** A stent according to claim 4, wherein:

said central portion of said stent includes eighteen to nineteen undulations.

**6.** A stent according to claim 1, wherein:

each winding includes three to five bridges extending therefrom.

8

**7.** A stent according to claim 1, wherein:

each of said bridges in said central portion extends in a same direction in a cylindrical plane of said stent.

**8.** A stent according to claim 7, wherein:

each of said bridges extends longitudinally crosswise across said helical space.

**9.** A stent according to claim 1, wherein:

said tubular member is self-expanding from said first diameter to said second diameter.

**10.** A stent according to claim 1, wherein:

said tubular member is a laser cut tube.

**11.** A stent according to claim 1, wherein:

said tubular member is made from a superelastic material.

**12.** A stent for insertion into a vessel of a patient, comprising:

a tubular member having a first smaller diameter for insertion into the vessel, and a second larger diameter for deployment within the vessel,

said tubular member including a central portion comprised of a plurality of helical circumferential windings separated by a helical space, each of said windings including a plurality of undulations, with each said undulation being defined by two adjacent struts and a loop connecting the struts,

wherein adjacent windings are connected with a plurality of bridges, said bridges extending across said helical space between said adjacent winding and connected to said loops of a plurality of said undulations,

wherein, for at least one of said windings, for any given number  $n$  of undulations on said winding and any given number  $b$  of bridges connected to said winding, where  $n \neq b$ , a maximum number of undulations is provided between said bridges, and further including,

a transition zone between said central portion and each of said cylindrical end portions, said transition zone including a plurality of transition undulations having struts that progressively increase in length,

wherein a relatively longer strut of said transition undulations has a relatively wider width than a relatively shorter strut of said transition undulations.

**13.** A stent according to claim 12, wherein:

said undulations on adjacent windings are interdigitated.

**14.** A stent for insertion into a vessel of a patient, comprising:

a tubular member having a first smaller diameter for insertion into the vessel, and a second larger diameter for deployment within the vessel, and defining a longitudinal axis, said tubular member including

a central portion comprised of a plurality of helical circumferential windings separated by a helical space, each of said windings including a plurality of undulations, with each said undulation being defined by two adjacent struts and a loop connecting said struts,

at least one cylindrical end portion at an end of said central portion, and

a transition zone between said central portion and each of said cylindrical end portions, said transition zone including a plurality of transition undulations having struts that progressively increase in length,

wherein a relatively longer strut of said transition undulations has a relatively wider width than a relatively shorter strut of said transition undulations.

**15.** A stent according to claim 14, wherein:

said tubular member has a longitudinal axis and adjacent struts of said transition zone are defined as a pair of struts, said transition zone having a plurality of said pairs, and



9

when said stent has said first smaller diameter, said struts of said central portion and said transition zone all extend substantially parallel to said longitudinal axis, and

when said stent has said second larger diameter, an angle is defined between said struts of each said pair of struts, and said angle is substantially the same for each said pair of struts.

16. A stent according to claim 14, wherein:

said longest strut of said transition undulations is 1.19 to 1.99 times wider than said shortest strut of said transition undulations.

17. A stent according to claim 14, wherein:

said longest strut of said transition undulations is approximately 1.59 times wider than said shortest strut of said transition undulations.

10

18. A stent according to claim 14, wherein:

said at least one cylindrical end portion is two cylindrical end portions.

19. A stent according to claim 14, wherein:

said struts of said central portion are all of a common length and width.

20. A stent according to claim 14, wherein:

said common length of said struts of said central portion is shorter than a shortest length of said struts of said transition undulations, and

said common width of said struts of said central portion is narrower than a narrowest width of said struts of said transition undulations.

\* \* \* \* \*